

LOFA MC704 and MC704 G4 Operation and Troubleshooting

Introduction

This document provides general information on LOFA Industries MC704 control systems operation and troubleshooting. MC704 control systems are a very flexible platform for diesel engine control, monitoring, and protection, featuring LOFA's powerful First Fault Diagnostics (FFD). After pinpointing the initial failure, FFD stores it in memory and alerts the end user via a single bright LED. FFD monitors battery charge, low oil pressure, high temperature and one additional contact closure input. The microprocessor-based solid-state design uses high-power semiconductors instead of outdated electromechanical relays to ensure reliable high-current switching.

The MC704 panels are offered in two versions. The MC704HP has a built-in tamperproof LED hourmeter while the reduced cost MC704LCP eliminates the hourmeter. The G4 variant includes up to four 2 inch gauges. All panel versions can be factory configured with specific preheat & afterglow requirements. If preheat is not required, this output can function as an alarm.

All standard panels include feature a 12 inch wiring harness terminating into a sealed weather proof plug. This robust universal wiring connection performs well in harsh environments and allows interchanging a number of different panels and harnesses. This design allows for simplified installation as well as a flexible means to incorporate custom plug-and-play engine wiring harnesses and standard harness extension

Note

The engine harness is not included with the panel.

A number of standard engine harnesses are available or LOFA can develop a custom harness for you exact needs.

Generic harnesses in various lengths are available for field customization.

Warning

When replacement parts are required, LOFA Industries recommends using replacement parts supplied by LOFA or parts with equivalent specifications.

Failure to heed this warning can lead to premature failure, product damage, personal injury or death.

Important Safety Information

The warnings in this publication are not all inclusive.

LOFA Industries cannot anticipate every potential hazard.

Appropriate safety rules and precautions should be followed with any tool, work method or operating procedure.

Improper procedures, tools and materials may cause damage or make the equipment unsafe to operate.

Only persons with appropriate training, skills and tools should perform these functions.

Improper operation, maintenance or repair of this product can be dangerous and may result in injury or death.

Do not operate or perform any maintenance or repair on this product until all operation, maintenance and repair information is read and understood.

The information, specifications, and illustrations in this publication are based on information available at the time of publication.

All items are subject to change at any time without notice.

Operation

Turning the control system key to the run position starts a self-test which causes all LEDs to flash three times, activates the alarm output (if preheat is not used) for one second and enables the fuel run/stop solenoid output. After self-test, the LEDs indicate the state of the inputs they monitor. The normal indications are battery charge and oil pressure on most applications. If these LEDs are not illuminated at this time it may indicate the inputs are not properly connected.

The Preheat/OK LED begins to blink when the key switch is turned to the run position if automatic preheat is configured (See Preheat Options). Preheat time varies from application to application. After waiting for the Preheat/OK LED to become solid, the engine is cranked by turning and holding the key switch in the start position until the engine starts. The key switch is spring loaded to return automatically to the run position when released.

Note

The key switch is equipped with a mechanical start locking device. An attempt to re-crank the engine can only be made by turning the key switch to the off position to reset the start locking mechanism.

If the engine is not started within 30 seconds of turning on the system, the fuel run/stop solenoid output is turned off to prevent battery discharge when the key switch is left in the run position. The fuel run/stop solenoid output is turned off after 30 seconds even if preheating. As soon as the key switch is turned to the start position the solenoid output is enabled. The afterglow cycle begins when the key switch returns to the run position.

Note

If conditions do not warrant preheat, the engine may be started by turning the key to the start position without waiting for the preheat time to expire.

Control system instrument power, including the hourmeter and voltmeter, is provided by the fuel run/stop solenoid output. If the instruments do not power up when the key is turned to the run position, this indicates a problem with the solenoid circuit (see Troubleshooting).

After the engine starts, the control system electronics ignore all shutdown conditions for the first 10 seconds. This delay eliminates the requirement to hold a by-pass override button during starting and allows the system conditions such as oil pressure to normalize. The 10 second timer starts when the key switch returns to the run position.

Note

Starter input is required for correct system operation. If the starter motor input is not activated (connected to battery positive) and the engine is started through another means (i.e. air starter) the engine will shutdown 30 seconds after the key switch is turned to the run position.

To prevent unintentional engine shutdowns caused by intermittent conditions (i.e., pressure spikes, coolant movement) the control system requires a constant 1/3 second fault input to cause engine shutdown.

Warning

When used in combination with mechanical float type switches engine vibrations may prevent constant contact closure.

Preheat Options

Preheat Output

Preheat is a 3A positive output for control of an external power relay with predetermined preheat and afterglow times. A relay should be selected with appropriate amperage capacity for the installed cold starting aid (glowplug, intake air heater, etc.). Applications using multiple cold starting aids may require multiple relays.

Note

Consult engine documentation when selecting cold starting aid, power relay and heating specifications.

Indicators



Battery LED (Red)

A solidly illuminated Battery LED indicates a battery charge failure. A battery charge failure may be caused by a faulty alternator, broken drive belt or the alternator not excited. A battery voltage reading of approximately 14 volts on a 12 volt system (28 volts on a 24 volt system) while the engine is running indicates the battery is charging properly. Irregular blinking of the Battery LED may indicate a failing charge circuit. The system can be configured for battery charge failure to indicate only.



Oil Pressure LED (Red)

A solidly illuminated Oil Pressure LED indicates low oil pressure failure. The control system typically senses low oil pressure from a ground contact switch on the engine. When a sender/switch combination is used on the engine, the marking **WK** generally indicates the switch terminal. This input typically expects a normally closed switch (ground contact when oil pressure is low). A defective switch or shorting the shutdown input to ground can cause low pressure fault indication. Additionally, when using sender/switch combinations, swapping the **WK** and **G** terminal can cause unintended shutdowns. The system can be configured for oil pressure failure to indicate only.

Warning

Low oil pressure is not an indication of low oil level.

For best possible protection LOFA recommends using our solid-state oil level shutdown switch.

Note

Most shutdown switches are grounded through the switch body.
Do not use insulating sealant (i.e. Teflon tape) when installing switches.



Temperature LED (Red)

A solidly illuminated Temperature LED indicates high engine temperature failure. The control system typically senses high temperature from a ground contact switch on the engine. When a sender/switch combination is used on the engine, the marking **WK** or **W** generally indicates the switch terminal. This input typically expects a normally open switch (ground contact when engine temperature is too high). A defective switch or shorting the shutdown input to ground can cause over temperature fault indication. Additionally, when using

sender/switch combinations, swapping the **WK** or **W** and **G** terminal can cause unintended shutdowns. The system can be configured for temperature failure to indicate only.

Warning

If the temperature switch is not in contact with coolant due to coolant loss the engine is not protected from overheating.

For best possible protection, LOFA recommends using our solid-state coolant level shutdown switch.

Note

Most shutdown switches are grounded through the switch body. Do not use insulating sealant (i.e. Teflon tape) when installing switches.

Some thermostat housings are composites and do not provide ground for the switch.



AUX LED (Red)

A solidly illuminated AUX LED indicates an auxiliary failure (i.e., coolant level, oil level, belt breakage, hydraulic pressure, etc.). The control system typically senses failure using a ground contact switch. Auxiliary inputs are equipment specific and determined by the equipment manufacturer. A defective switch or shorting the shutdown input to ground can cause fault indications. The system can be configured for auxiliary failure to indicate only.

Preheat/OK LED (Green)

A blinking green Preheat/OK LED is the system preheat indication. When the LED changes to solid the preheat period is complete and the engine may be cranked. The LED changes to solid illumination when the engine starts. There is no indication of afterglow.

Harness

Sealed Connectors

The provided sealed weather proof plug includes a grey locking device which must be released to separate the connectors. Press the tab on the connector housing to release the connectors.

Warning

LOFA does not recommend using dielectric grease or sealant with sealed connectors.
These chemicals may cause seal damage and allow water entry.

Use LOFA provided cavity plugs to seal the connector if wires are removed.

Unsealed Connectors

For unsealed connectors exposed to the elements, LOFA recommends using dielectric grease to protect contacts.

Warning

LOFA does not recommend using sealant with unsealed connectors.
Sealant traps moisture in the connector and encourages corrosion.

Harness Routing

The minimum routing of radius of the wiring harnesses should be at least two times the diameter of the wiring harness. Bends should be avoided within 1 inch (25 mm) of any connector in order to avoid seal distortion allowing moisture to enter the connector.

Note

For harness length in excess of 10 ft a relay must be added to the start solenoid circuit.

LOFA offers starter relay kits for mounting near the engine.

Battery Circuit Requirements

Battery Positive Connection

The electronic control system operates on either a 12 VDC or 24 VDC electrical systems. The unswitched battery positive connection to the control system is made at the weather proof connector. The control system provides switched positive battery

Protection for the unswitched battery positive circuit is dependent on specific equipment configuration. The overload protection should not exceed 125% of the sum of all output currents plus 5 Amps for the control system. Powering the control system through dedicated circuits with appropriate overload protection reduces the possibility of system damage.

Circuit breakers are preferred over in-line fuses for circuit protection. Over current protection devices should ideally be located in a central location. If automatic reset circuit breakers are used, consideration of the environment of the breaker is critical and may affect the trip point. The trip point of some circuit breakers can be significantly reduced below the rated trip point if the circuit breaker is exposed to high temperatures.

Warning

Disconnecting the battery while the engine is running may damage electrical components.

When using a battery disconnect switch, LOFA recommends using a 2 pole switch to disconnect both the battery and alternator output.

Battery Negative Connection (Grounding)

Warning

Improper grounding can cause electrical noise, unreliable operation and may damage the control system or other components. All ground connections must be free from foreign materials, including paint, which may interfere with proper grounding.

A reliable ground must be provided for the control system.
LOFA recommends the ground connection be made directly to the battery negative.
Grounding through frame members is not recommended.

All ground paths must be capable of carrying any likely fault currents.

Do not reverse the battery polarity. Attempting to crank the engine when the polarity of the battery connections is reversed may damage the control system.

Note

A maximum of three ring terminals should be connected to a ground stud in order to ensure integrity of the ground connection. The use of more than three terminals can cause the connection to become loose.

Voltage Drop

If control system voltage drops below 6 volts for more than one tenth of a second, the control system may reset causing the self test to reactivate and the engine to shutdown after 30 seconds. Resetting the control

system is equivalent to quickly turning the key switch to off and back to run without starting the engine. Since the control system did not sense a start signal, the fuel run/stop solenoid deactivates after 30 seconds. Voltage drops can be caused by transients from external equipment, improper wire sizes, faulty wiring or nearby lightning strikes. In the absence of a *LOFA Power Box*, relays may be needed for long wire runs.

Suppression of Voltage Transients (Spikes)

Warning

The installation of voltage transient suppression at the transient source is required.

LOFA follows SAE recommended electrical environment practices.

Inductive devices such as relays, solenoids and motors generate voltage transients and noise in electrical circuits. Unsuppressed voltage transients can exceed SAE specifications and damage electronic controls.

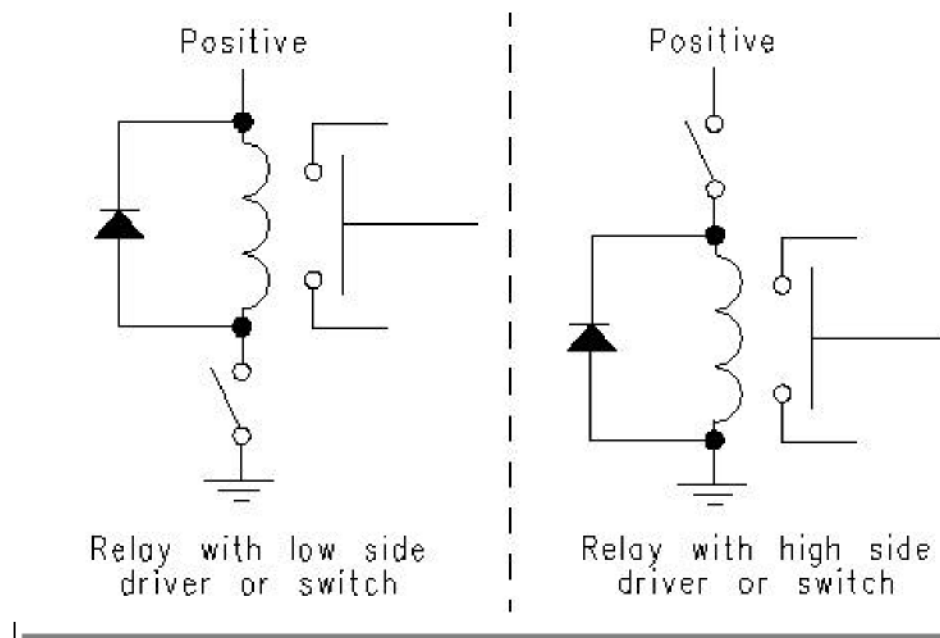

Relays and solenoids with built-in voltage transient suppression diodes are recommended whenever possible. Refer to the illustration for proper installation of diodes when built-in voltage transient suppression is not available.

Locate inductive devices as far as possible from the components of the electronic control system. When using electric motors it may also be necessary to add isolation relays to eliminate voltage transients, noise and prevent back feed.

Note

LOFA harness assemblies typically include all required engine control suppression devices. Added equipment will require additional protection.

Welding on Equipment with Electronic Controls

Proper welding procedures are required to avoid damage to electronic controls, sensors, and associated components. The component should be removed for welding if possible.

The following procedure must be followed if the component must be welded while installed on equipment with electronic controls. This procedure will minimize the risk of component damage.

Warning

Do not ground the welder to electrical components such as the control ground or sensors.
Improper grounding can cause damage to electrical components

Clamp the ground cable from the welder to the component being welded. Place the clamp
as close as possible to the weld to reduce the possibility of damage.

1. Stop the engine. Turn the key switch to the OFF position.
2. Disconnect the negative battery cable from the battery.
3. Open any installed battery disconnect switch.
4. Unplug the control system if possible.
5. Connect the welding ground cable as close as possible to the area to be welded.
6. Protect the wiring harness from welding debris and spatter.
7. Use standard welding methods to weld the materials.

General Troubleshooting

For additional information, refer to engine manufacturer troubleshooting guide.

No response from starter motor

Possible Cause	Possible Remedy
No battery voltage to starter	Verify wiring and battery connection (power and ground)
Battery discharged	Charge or replace battery, verify alternator charging
Tripped overcurrent protection	Correct fault, replace or reset overcurrent protection
No signal from control system	No power to control system (see Control System Troubleshooting below)
Defective starter solenoid	Replace starter solenoid
Defective starter motor	Replace starter motor

Engine will crank but not start

Possible Cause	Possible Remedy
Engine not getting fuel	Check fuel level, filter, fuel pump, verify no air in fuel lines
Fuel run/stop solenoid not engaged	See Fuel Solenoid Run/Stop Troubleshooting (below)
Tripped overcurrent protection	Correct fault, replace or reset overcurrent protection
No preheat (cold condition)	See Preheat Troubleshooting

Engine runs for 10 seconds and shuts down

Possible Cause	Possible Remedy
Shutdown switch input active	Verify shutdown source exists, correct condition or correct faulty circuit
Battery not charging	Verify alternator charging (see Alternator not charging battery below)
Control board did not sense start signal	Engine started through alternate method (i.e., manual air start, push start, etc.)
Defective control system	See Control Panel Troubleshooting (below)

Engine runs longer than 10 seconds and shuts down

Possible Cause	Possible Remedy
Shutdown switch input active	Correct engine fault, verify shutdown switch wiring
Circuit overload protection tripped	Correct overload, keep control system from overheating (over 185° F/85° C)
Voltage transients (spikes)	Add suppressor diodes, protect from nearby lightning strikes, shield induced spikes from other equipment, add electric motor control relay
Defective control system	See Control System Troubleshooting (below)

Alternator not charging battery

Possible Cause	Possible Remedy
Broken or slipping alternator drive belt	Adjust or replace alternator drive belt
Alternator not excited	Verify excitation circuit connected, replace faulty regulator, add additional excitation resistor
Alternator output not connected	Install charge wire
Alternator not grounded	Clean or add ground connection
Alternator faulty	Replace faulty alternator

Fuel Run/Stop Solenoid Troubleshooting**Engine does not stop immediately**

Possible Cause	Possible Remedy
Back feed from motor (i.e., cooling fan)	Add relay or blocking diode
Sticking solenoid linkage	Repair or replace solenoid linkage
Fuel valve without check valve	Install or repair check valve

Fuel run/stop solenoid does not engage

Possible Cause	Possible Remedy
No power to solenoid	Locate reason for lack of power and correct (Circuit overloaded? Failed suppressor diode? Faulty wiring?)
No power to solenoid pull coil	Correct faulty wiring, check pull control circuit (see Power Box Troubleshooting below)
Incorrect linkage adjustment	Adjust solenoid linkage
Faulty solenoid	Replace solenoid
Failed suppressor diode	Correct wiring (diode reversed?), replace suppressor diode
Optional e-stop engaged	Disengage e-stop

Engine not getting fuel

Possible Cause	Possible Remedy
Empty fuel tank	Fuel engine
Clogged filter	Replace filter
Air in fuel lines	Bleed fuel lines
Low fuel pressure	Replace faulty fuel pump and/or clogged filter
Faulty fuel pump	Replace fuel pump, correct wiring fault (electric fuel pump)

Preheat Troubleshooting**Engine is hard to start in cold conditions**

Possible Cause	Possible Remedy
Start attempt before preheat complete	Wait for preheat time to elapse, crank as soon as time elapses
Incorrect preheat specification	Correct control system configuration, install correct control system
Heater faulty	Replace heater
Heater relay faulty	Replace relay
Preheat control not functioning	Correct wiring, correct control system configuration
Faulty control system	See Control System Troubleshooting (below)

Engine produces excessive white smoke after starting

Possible Cause	Possible Remedy
Afterglow not enabled	Reconfigure control system
Heater faulty	Replace heater
Heater relay faulty	Replace relay
Preheat control not functioning	Correct wiring, correct control system configuration
Faulty control system	See Control System Troubleshooting (below)

Control System Troubleshooting

Control system does not perform self test

Possible Cause	Possible Remedy
Tripped overcurrent protection	Correct fault, replace or reset overcurrent protection
Faulty connection to battery	Correct battery connections (see Battery Circuit Requirements above)

Control system performs normal self test, engine cranks, runs and shuts down

Possible Cause	Possible Remedy
Only Battery LED illuminated	Correct battery charge failure (see Battery not charging above)
Only Oil Pressure LED Illuminated	Correct low oil pressure condition or faulty switch, correct wiring fault
Only Temperature LED Illuminated	Correct overheating condition or faulty switch, correct wiring fault
Only Aux LED Illuminated	Correct fault condition (i.e. v-belt, coolant level) or faulty switch, correct wiring fault
All normally closed shutdowns illuminate for one second (control system reset)	Add suppressor diodes, protect from nearby lightening strikes, shield induced spikes from other equipment, add electric motor control relay

Testing Shutdown Inputs

Shutdown switches signal a fault by ground contact in most systems. Shutdown operation can be verified by grounding the shutdown inputs individually. It may be necessary to remove the wire from the shutdown switch to perform this test.

Note

Most shutdown switches are grounded through the switch body.
Do not use insulating sealant (i.e. Teflon tape) when installing switches.

Some thermostat housings are composites and do not provide ground for the switch.

" Power Box Option

The Power Box is a solid state, high current control system for mechanically governed, industrial diesel engines. In addition to allowing extended harnesses, the Power Box provides 3-wire fuel run/stop solenoid control to protect the pull coil from overheating. Power Box technology typically controls the starter solenoid, fuel run/stop solenoid and cold starting aid. All outputs are overload protected and the system is fused to avoid damage in the event of excess current demand. An additional fuse protects the control circuitry.

Warning

The Power Box is reverse polarity protected but may be damaged by attempting to start the engine with battery polarity reversed.

When the fuel solenoid input is enabled, the fuel run/stop solenoid pull coil is enabled for the first second. In normal operation, all other Power Box outputs are active as long as their corresponding inputs are active.

Power Box Troubleshooting

One output never activates

Possible Cause	Possible Remedy
Input not active	See Control System Troubleshooting (above)
Output shorted	Correct fault
Failed Power Box	Replace Power Box/harness assembly

All outputs never activate

Possible Cause	Possible Remedy
Blown fuse(s)	Correct fault, replace fuse(s)
Faulty connection to battery	Correct battery connections (see Battery Circuit Requirements above)
Failed Power Box	Replace Power Box/harness assembly

Fuel run/stop solenoid pull output remains active

Possible Cause	Possible Remedy
Faulty wiring	Correct wiring
Faulty connection to battery	Correct battery connections (see Battery Circuit Requirements above)
Failed Power Box	Replace Power Box/harness assembly

Revision History

Initial Release.

Rev A – 22-May-2006. Corrected typographical errors.

Rev B – 26-Oct-2006. Add symbols to *Indicators*, corrected typographical errors.

Rev C – 8-Jan-2007. Updated schematics

Rev C.1 – 28-Feb-2007. Added part numbers.

Typical Schematics

The following pages show typical schematics.

Details vary from installation to installation.

See the specific schematics for installation for details.

Need MC704 GT Panel Drawing

LOFA MC704 and MC704 G4 Operation and Troubleshooting

THE INFORMATION CONTAINED IN THIS DRAWING IS CONFIDENTIAL AND THE SOLE PROPERTY OF LOFA INDUSTRIES INC. Reproduction or dissemination in whole or in part in any form or medium without express prior/written permission of LOFA INDUSTRIES INC is prohibited.

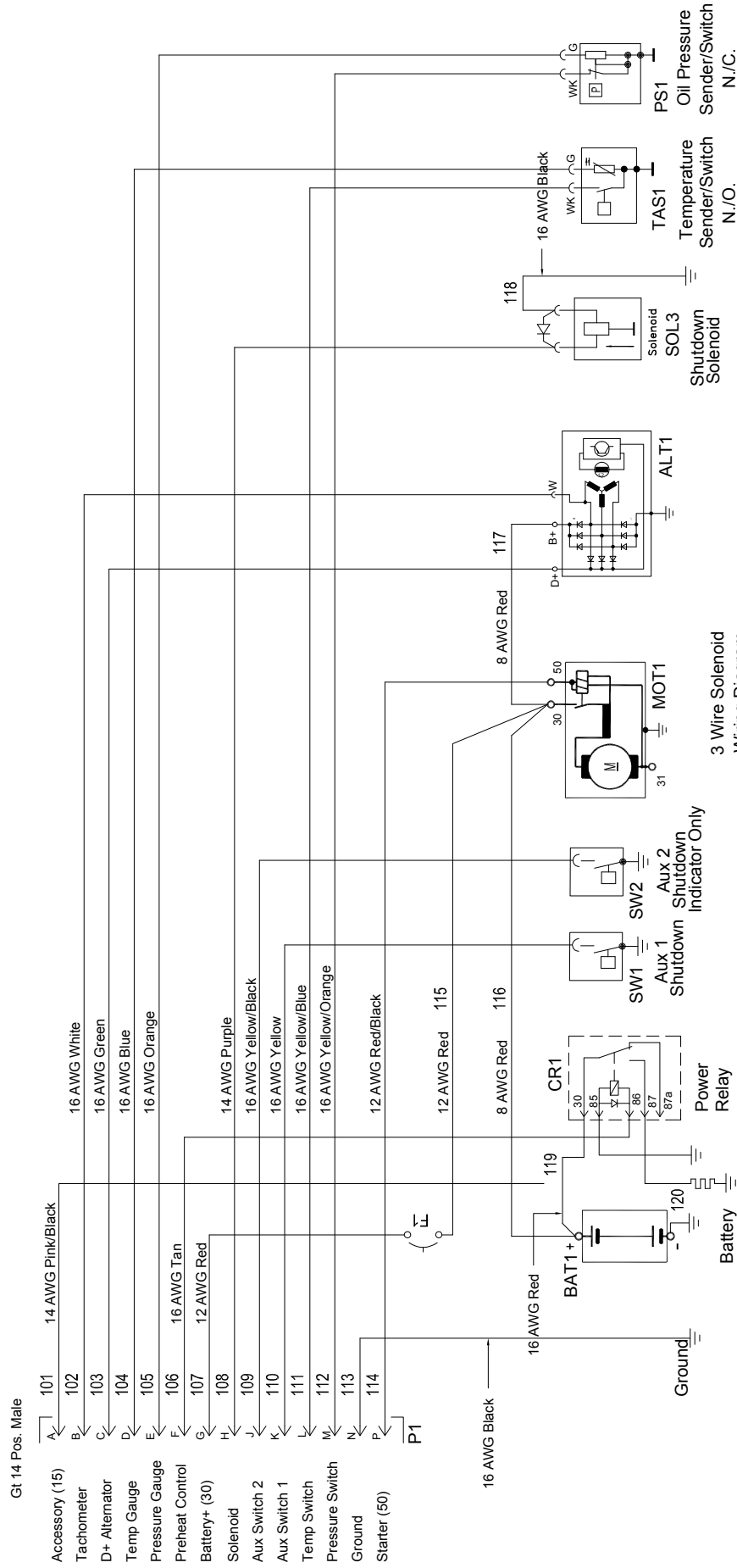

Note: -WK = Switch
-G = Gauge

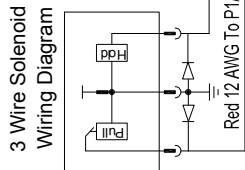
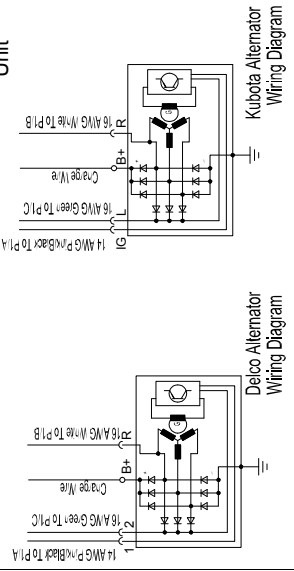

Description: MC-538 Engine Generac Diagram With GT Male		Tolerances		X .XX .XXX		ANG*	
Part Number:		+/-		.1 .02 .005		2"	
Rev		Date:		Sheet 1 of 1		www.LOFA.net	
Roswell GA 30076		phone: 770-569-9828		fax: 770-569-9829			